

Optical inspection

Type: OI2pro

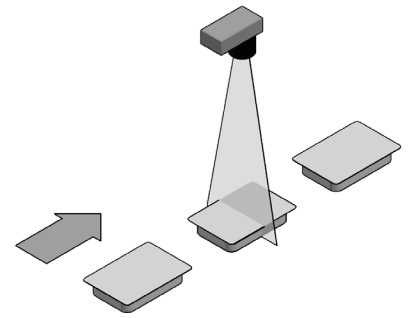

Type: OI2pro

OPTICAL INSPECTION FOR HIGH-RANGE PERFORMANCE

Simple

The clearly arranged and intuitive handling simplifies your employees' daily work on the inspection system.

Flexible

The project-related implementation of the inspection system is modular and cost-optimized to the specific requirements of your application.

High performance

The inspection system enables single- or dual-sided film and label inspection, including presence and position checks, inspection of contents, inspection for damage and much more at a performance of up to 200 products per minute. It guarantees 100% control of your production quantities. A manual sample control is no longer necessary.

Complete integration

A wide variety of interfaces to upstream and downstream line components, to data acquisition systems or to your enterprise resource planning system enable a high degree of automation as well as optimized data acquisition and evaluation (industry 4.0).

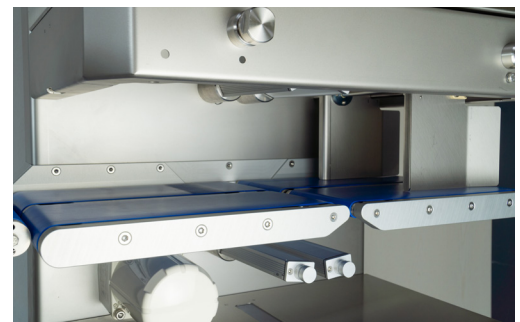
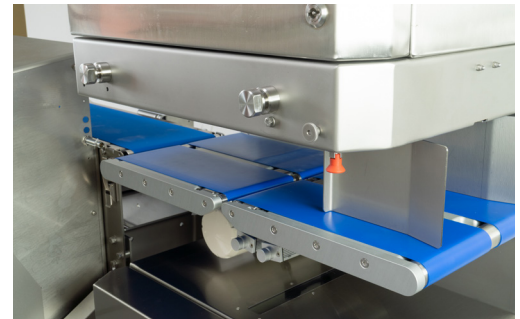

OPTIONS

- Camera inspection of top AND/OR bottom
- OCV (optical character verification) of top AND/OR bottom
- Presence control with luminescence scanner
- Single or dual track system possible
- Control features (presence, position, plausibility, readability of patterns, BBD, barcode, QR codes, lot labels, ...)
- Operating side left / right
- Ejection monitoring
- Fill level monitoring of ejection container

Type: OI2pro

TECHNICAL DATA / DIMENSIONS

| | |
|--|---|
| Performance | 200 products / min depending on product dimensions and inspection details |
| max. product length | 340 mm |
| max. product width | 280 mm |
| max. product height | 100 mm |
| max. product weight | 1.500 g |
| Length in line | 1.267 mm (product length < 260 mm) 1.367 mm (product length < 340 mm) |
| Infeed / Outfeed height | 800 – 1.000 mm |
| Belt system | PU-belt self-centering |
| Operating side | left / right |
| Operation | Touchpanel 15" |
| Velocity | 40 – 75 m/min |
| Protection class | IP54 |
| Temperature range | +5°C to +30°C |
| Product parameter memory | 100 |
| Material | Stainless steel frame |
| Interfaces | 2 Outputs (relay) <ul style="list-style-type: none"> ▪ system ready/not ready ▪ system running/not running 2 Inputs (optically isolated) <ul style="list-style-type: none"> ▪ external release ▪ external start/stop Network RJ45 (OPC-UA optional) |
| Rated voltage | L/N/PE 230 VAC |
| Nominal frequency | 50 Hz |
| Power supply | ca. 1 kVA |
| Compressed air supply (ejection system) | min. 6 bar, ISO 8573-1:2010 [7:4:4], quick coupling plug NW 7,2 consumption: 0,05 l/eject |
| Drives | Asynchronous drives |

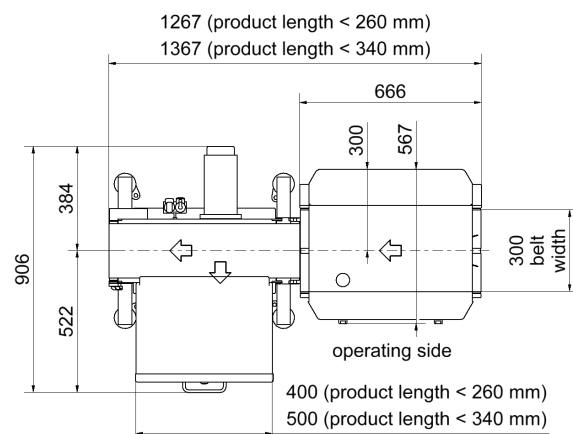
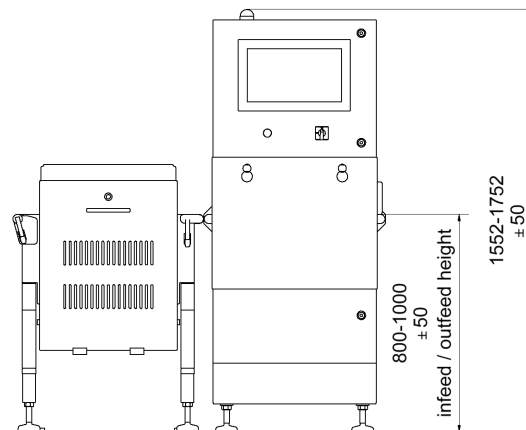

Type: OI2pro

NOTES

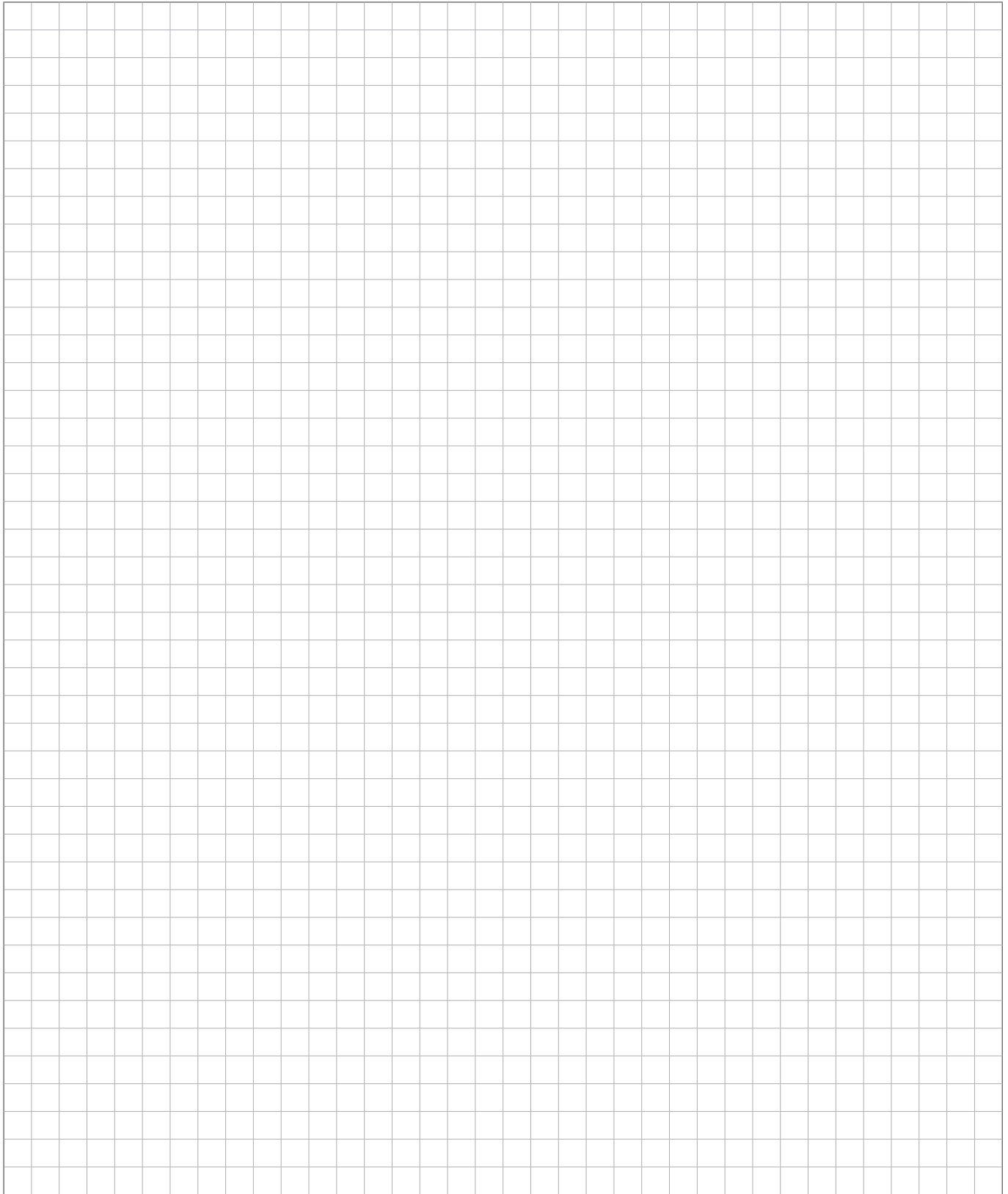

Version: 2302eng | Typing and printing errors reserved. Subject to changes.