

# Checkweigher

Type: CW-M / CCW-M

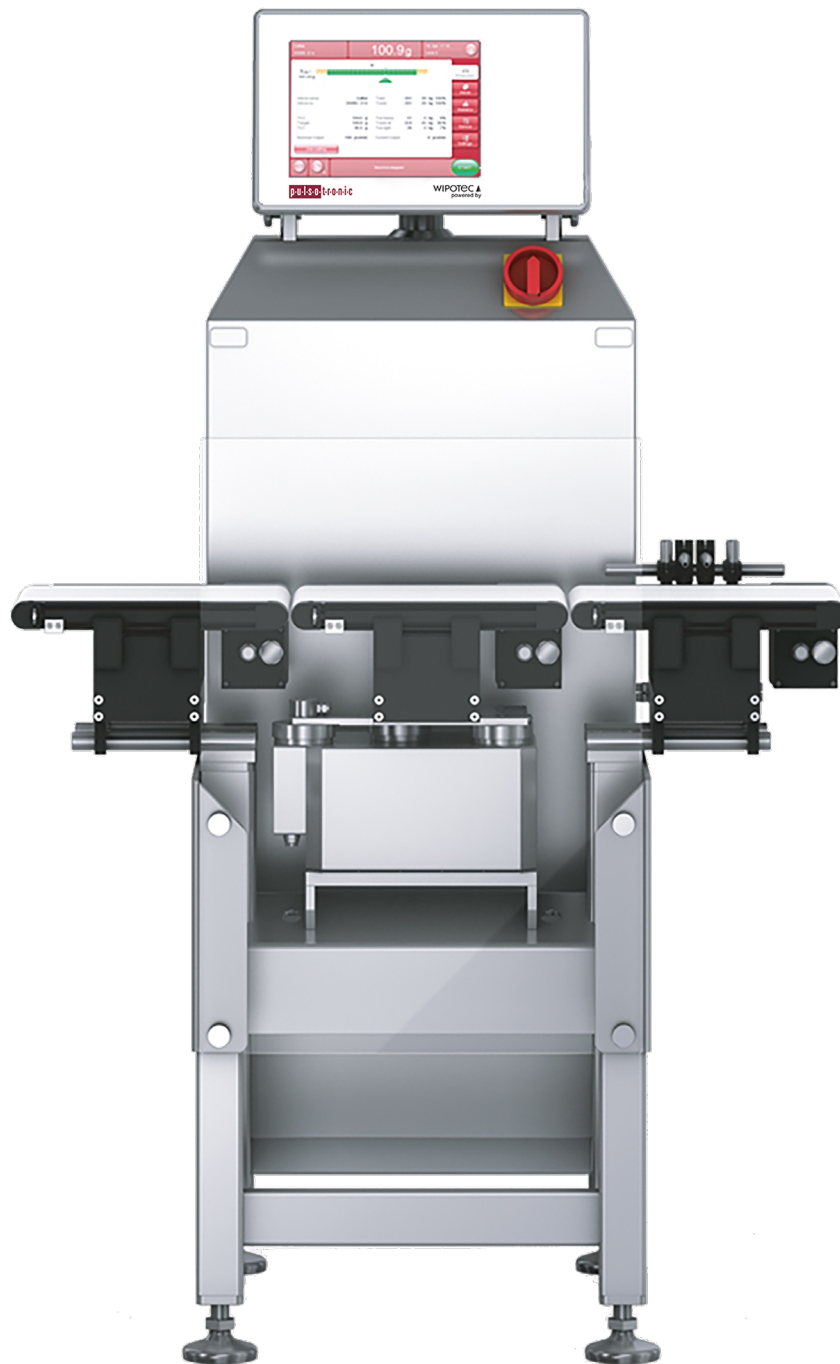

# Type: CW-M / CCW-M

## HIGH PRECISION WEIGHING FOR MEDIUM SPEED APPLICATIONS

The dynamic **CW-M** checkweigher is the ideal medium speed weighing solution for a wide range of checking, regulation and control tasks. CW-M machines are capable of 250 weighing operations per minute.

The CW-M checkweigher offers you operator-friendly solutions. It doesn't matter whether you want to check the current actual weight, carry out a completeness check on your products or perform sorting or classification. The sturdy base frame made of stainless steel enables high weighing accuracy at medium belt speeds or throughput rates.

Checkweighers from Pulsotronic are a by word for 100% product monitoring. The lightweight, patented conveyor systems and the particularly carefully coordinated drive concept ensure optimum smoothness with quiet running and fast, safe product transport. Individually adapted solutions can be implemented in a modular fashion for a wide range of pro-

duct shapes. A sophisticated and wide spectrum of sorting devices (e.g. pusher, air blast nozzles) is available to reject products with incorrect weight reliably and without disturbing production.

Optionally, the checkweigher is also available as Kombichecker CCW-M – a combination with metal detector.

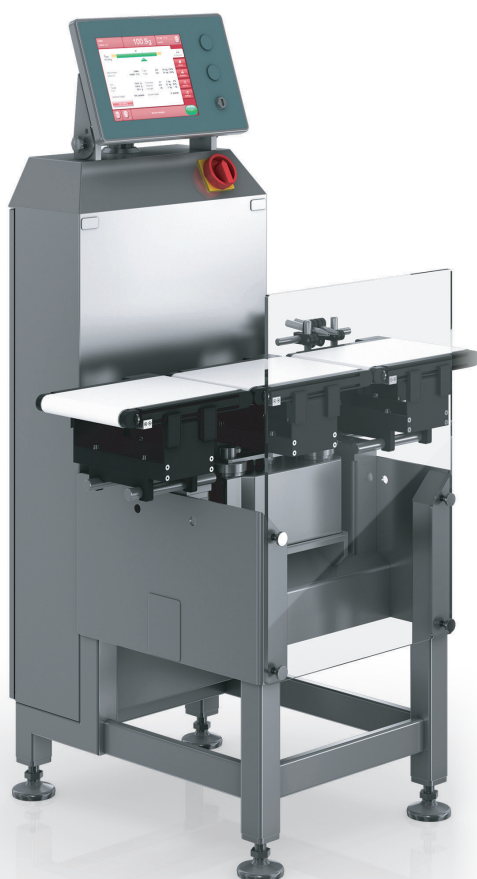

### MAIN FEATURES

- ✓ entire machine in stainless steel housing with infeed, weighing, and outfeed belts (NT30)
- ✓ maintenance-free servo drives
- ✓ certified (MID)
- ✓ WIPOTEC EMFR Weigh Cells
- ✓ simple, menu-directed operation on 10.4" colour TFT touchscreen
- ✓ memory for 100 product parameters
- ✓ easy, tool-free exchange of belts and conveyors
- ✓ line synchronisation with potential-free I/O signals
- ✓ extensive statistical functions/histograms for production documentation
- ✓ optionally available in combination with metal detector (CCW-M)

### YOUR BENEFITS

- ✓ maximum throughput 250 pcs/min
- ✓ exact fill results for higher productivity
- ✓ efficiency improvement through simple and user-friendly controls
- ✓ requirements-based modularity for the greatest flexibility

# Type: CW-M / CCW-M

## TECHNICAL DATA

### BASE DATA

Material of machine	frame stainless steel V2A/AISI 304
Machine weight (standard application)	230 kg
Shipping weight (standard application)	300 kg
Protection class	IP54 <sup>1)</sup>
Temperature range	+5°C bis +40°C
Display and operation	tiltable 10,4" colour TFT display with touchscreen
Available dialog languages	Bosnian, Chinese, Croatian, Czech, Danish, Dutch, English, Finnish, French, German, Greek, Hungarian, Italian, Japanese, Latvian, Lithuanian, Polish, Portuguese, Russian, Slovak, Slovenian, Spanish, Swedish, Turkish (other languages on request)
Interfaces <sup>2)</sup>	optionally: Ethernet, OPC, Profibus, ProfiNet, EtherNet/IP, RS232, RS422, RS485
max. output <sup>3)</sup>	250 pcs / min
Digitale I/O	8xE + 8xA (optionally extendible)
Product parameter storage	100 PPS (optionally 200 / 400 PPS)
Drive	Servo-Technology
Noise level <sup>3)</sup>	A-weighted emission sound pressure level under 70dB(A)
Rated voltage	L1/N/PE 100-240 VAC
Rated frequency	50/60 Hz
Connect load (power capacity)	approx. 0.8 kVA
Compressed air supply (option)	6 bar approx. 16NI/min quality class (according to ISO 8573-1) [5:3:3]
Possible maximum numbers of connected motors	3 motors (optionally 2 extendible)
EU-type examination certificate	DE-18-MI006-PTB001 (MID)

### WEIGHING DETAILS

	Weigh Cell (type)	GWR (gross weighing range)	Dead load (max.)	e (min, calibration value)	d (displayed value)	Standard deviation <sup>3)</sup> (1s)	n (scale division)
<b>CW-M-2000-2</b>	EC-2000-2	750 g	4,000 g	≥ 0.1 g	≥ 0.01 g	from 100 mg	7,500
<b>CW-M-2000-1</b>	EC-2000-1	1,500 g	4,000 g	≥ 0.2 g	≥ 0.02 g	from 100 mg	7,500
<b>CW-M-3000-3</b>	EC-3000-3	1,500 g	8,500 g	≥ 0.2 g	≥ 0.02 g	from 100 mg	7,500
<b>CW-M-3000-2</b>	EC-3000-2	3,750 g	8,500 g	≥ 0.5 g	≥ 0.05 g	from 100 mg	7,500
<b>CW-M-3000-1</b>	EC-3000-1	7,500 g	8,500 g	≥ 1.0 g	≥ 0.1 g	from 100 mg	7,500
<b>CW-M-4000-2</b>	EC-4000-2	7,500 g	15,000 g	≥ 1.0 g	≥ 0.1 g	from 100 mg	7,500

### DIMENSIONS CONVEYOR

		Dimensions weighing conveyor				
length	width	120 mm	150 mm	200 mm	300 mm <sup>2)</sup>	400 mm <sup>2)</sup>
	200 mm	x	x	-	-	-
250 mm <sup>2)</sup>	x	x	x	-	-	-
300 mm	x	x	x	-	-	-
400 mm	x	x	x	x	-	-
500 mm <sup>2)</sup>	x	x	x	x	x	x

1) Water from above, for IP65 full protection, see VA-application or WD-application (IP69K)

2) optionally, surcharge

3) Depending on product shape, product behavior, transport speed and environmental condition

# Type: CW-M / CCW-M

## TECHNICAL DATA

### DIMENSIONS CONVEYOR

		Dimensions infeed / outfeed conveyor				
length \ width		120 mm	150 mm	200 mm	300 mm <sup>2)</sup>	400 mm <sup>2)</sup>
200 mm		X	X	-	-	-
250 mm		X	X	X	-	-
300 mm		X	X	X	X	-
400 mm		X	X	X	X	X
500 mm		X	X <td X	X	X	

## MACHINE DIMENSIONS CW-M

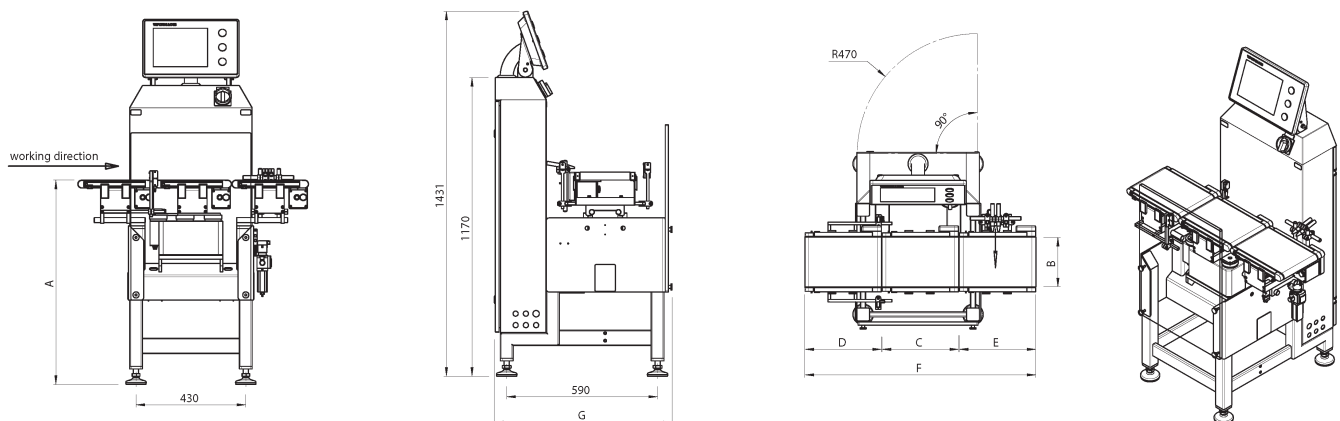

- A Working height** <sup>1)</sup> 700 – 850 / 800 – 950 / 900 – 1.050 mm
- B Conveyor width** 120 / 150 / 200 / 300<sup>2)</sup> / 400<sup>2)</sup> mm  
roller diameter 30 mm
- C Weighing conveyor length** 200 / 250<sup>2)</sup> / 300 / 400 / 500<sup>2)</sup> mm
- D Infeed conveyor length** 200 / 300 / 400 / 500 / 600 mm
- E Outfeed conveyor length** 200 / 300 / 400 / 500 / 600 mm
- F Total length** D + C + E + 10 mm
- G Total width** 700 mm depending on machine configuration

## ALTERNATIVE TYPE CCW-M

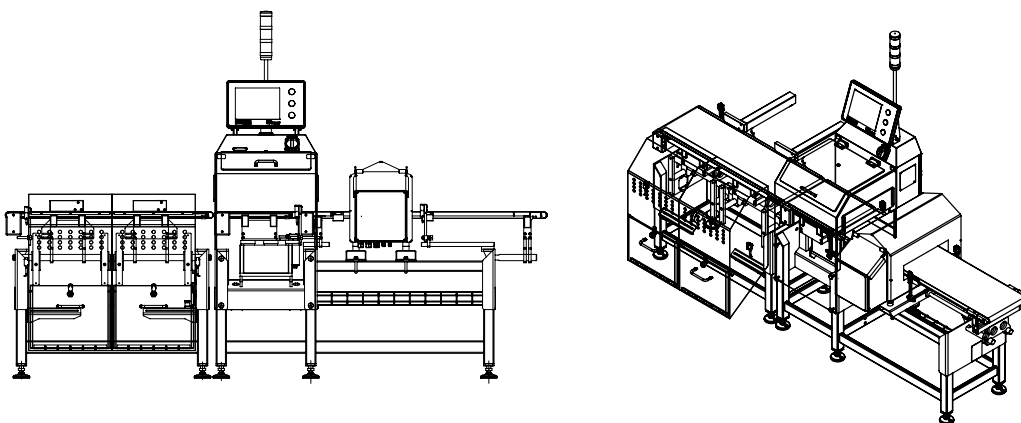

- 1) Working height must be specified when ordering
- 2) Optionally, surcharge

These specifications are reference values of the standard machine excluding application- or weighing-specific add-on parts. All entries in mm | Drawing shows design example

Version: 2301eng | Typing and printing errors reserved. Subject to changes.